

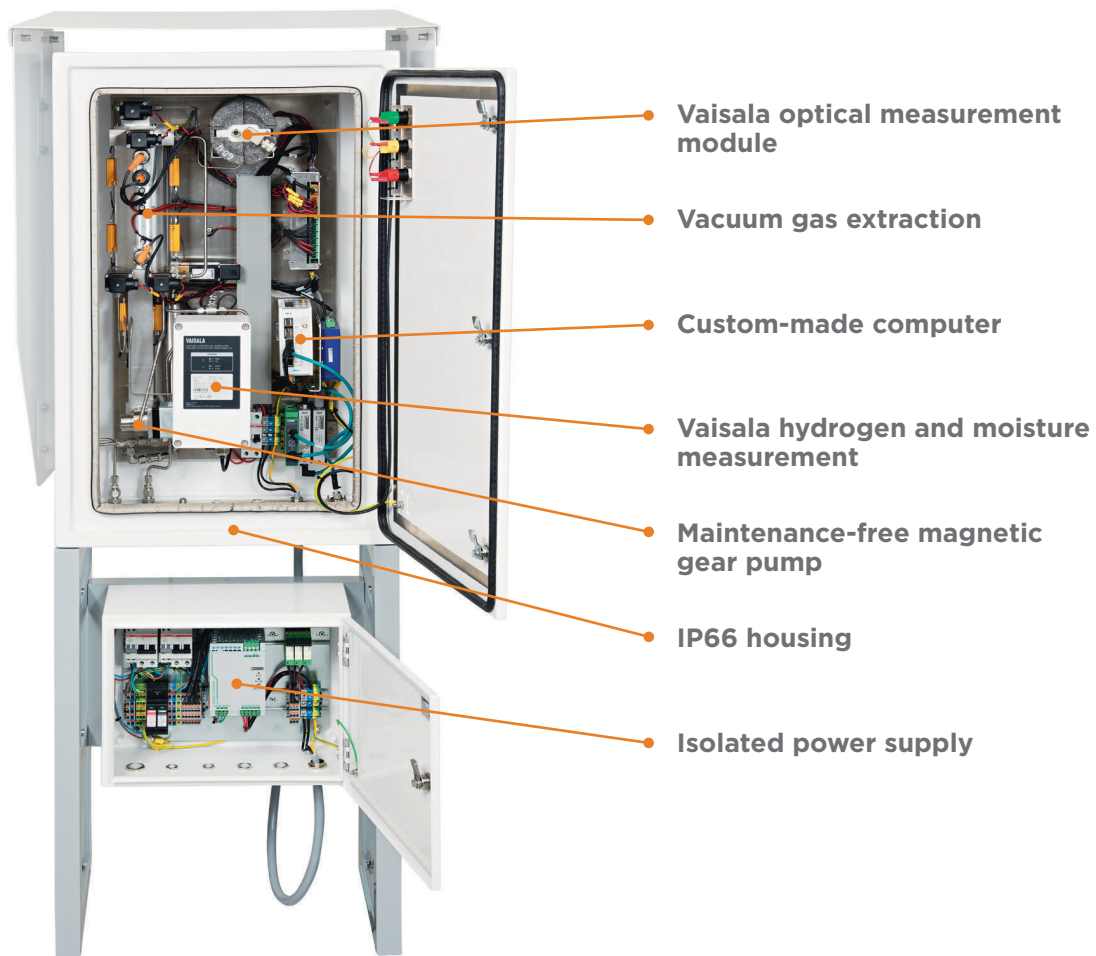

## How is the Vaisala Optimus™ OPT100 DGA Monitor Different?



### Better Measurement Performance

- Optical IR sensors designed and manufactured in Vaisala cleanrooms
- Spectral scanning provides selective gas measurement
- Vacuum gas extraction independent of oil temperature and pressure
- Unique auto-calibration eliminates long-term drifts – no need to recalibrate

### More Robust Design

- Hermetically sealed structure tolerates vacuum and pressure variation
- Stainless steel and aluminum components and piping in contact with oil
- No consumables means no regular maintenance
- Magnetic drive gear pump and high quality valves for durability

### Simplified Installation and Operation

- Installation and commissioning in as little as two hours
- Continuous operation with roughly one-hour output interval – no data averaging needed
- Browser-based user interface to easily view and share data, and change settings
- Self-diagnostics with self-recovery after disturbances



Optimus DGA Monitor is the right solution for safeguarding critical transformers in harsh environments

## Prevent Power Transformer Failure

There's nothing worse than an unplanned outage, in terms of both lost revenue and the incalculable costs to your reputation and brand. The good news is that over 50 percent of power transformer faults can be detected with the right online monitoring tools, meaning that severe failures can be prevented. But monitors that give false alarms or require regular maintenance can end up wasting considerable amounts of your time and money.

That's why we created the Vaisala Optimus™ DGA Monitor. It provides real-time, trouble free fault gas monitoring for your power transformers – with no false alarms or maintenance.

The two key design drivers have been safety and reliability in demanding operating environments. This is the culmination of decades of listening to customers' needs and researching

existing devices, as well as leveraging our 80 years of experience making sensors and measuring equipment for safety-critical industries and harsh environments.

## Dependable Data with No False Alarms

The IR sensor is based on Vaisala core measurement technology and components manufactured in our own cleanroom. Vacuum gas extraction means no data fluctuation due to oil temperature or pressure, while hermetically sealed and protected optics prevent sensor contamination. Moisture is measured directly in the oil with our capacitive thin-film polymer HUMICAP® sensor, which has been used for transformer monitoring for 20 years. Hydrogen is also measured directly in the oil with the same solid-state sensor technology used in the Vaisala MHT410.

## Robust Construction

Stainless steel pipes, IP66-rated and temperature-controlled housing, as well as a magnetic drive gear pump and valves mean superb performance and durability – from the arctic to the tropics. What's more, there are no consumables to service or replace.

## Smart Design

Vaisala Optimus™ DGA Monitor has a web-based user interface that completely eliminates the need for additional software. The device is designed to be installed in less than two hours – just connect the oil, power, and data connections, and it's ready to go. It can be connected to an existing control and monitoring system via digital communication and relays, or used as a standalone monitoring device. And in case of a disturbance such as a power outage, self-diagnostics allow for self-recovery.

# Technical Data

## Measured Parameters in Oil

Parameter	Range	Accuracy <sup>1) 2)</sup>	Repeatability <sup>2)</sup>
Methane (CH <sub>4</sub> )	0 ... 10 000 ppm <sub>v</sub>	10 ppm or 10 % of reading	10 ppm or 5 % of reading
Ethane (C <sub>2</sub> H <sub>6</sub> )	0 ... 10 000 ppm <sub>v</sub>	10 ppm or 10 % of reading	10 ppm or 5 % of reading <sup>3)</sup>
Ethylene (C <sub>2</sub> H <sub>4</sub> )	0 ... 10 000 ppm <sub>v</sub>	10 ppm or 10 % of reading	10 ppm or 5 % of reading
Acetylene (C <sub>2</sub> H <sub>2</sub> )	0 ... 5000 ppm <sub>v</sub>	2 ppm or 10 % of reading	1 ppm or 10 % of reading
Carbon monoxide (CO)	0 ... 10 000 ppm <sub>v</sub>	10 ppm or 10 % of reading	10 ppm or 5 % of reading
Carbon dioxide (CO <sub>2</sub> )	0 ... 10 000 ppm <sub>v</sub>	10 ppm or 10 % of reading	10 ppm or 5 % of reading
Hydrogen (H <sub>2</sub> )	0 ... 5000 ppm <sub>v</sub>	25 ppm or 20 % of reading	15 ppm or 10 % of reading
Moisture <sup>4)</sup> (H <sub>2</sub> O)	0 ... 100 ppm <sub>w</sub> <sup>5)</sup>	±2 ppm <sup>6)</sup> or ±10 % of reading	Included in accuracy

1) Accuracy specified is the accuracy of the sensors during calibration gas measurements. Accuracy of the gas-in-oil measurement may also be affected by oil properties and other chemical compounds dissolved in oil.

2) Whichever is greater.

3) Repeatability of ethane measurement is specified with averaging of five measurements.

4) Measured as relative saturation (%RS).

5) Upper range limited to saturation.

6) Calculated ppm value is based on average solubility of mineral oils.

## Measurement Performance

Measurement cycle duration	1 ... 1.5 h (typical)
Response time (T63)	One measurement cycle <sup>1)</sup>
Warm-up time until first measurement data available	Two measurement cycles
Initialization time to full accuracy	Two days
Data storage	At least 10 years
Expected operating life	> 15 years

1) Three cycles for ethane and hydrogen.

## Calculated Parameters

Total dissolved combustible gases (TDCG)	Combined total of H <sub>2</sub> , CO, CH <sub>4</sub> , C <sub>2</sub> H <sub>6</sub> , C <sub>2</sub> H <sub>4</sub> , and C <sub>2</sub> H <sub>2</sub>
Rate of change (ROC)	Available for single gases and TDCG for 24 h, 7 d, and 30 d periods
Gas ratios <sup>1)</sup>	Available ratios: <ul style="list-style-type: none"> <li>• CH<sub>4</sub>/H<sub>2</sub></li> <li>• C<sub>2</sub>H<sub>2</sub>/C<sub>2</sub>H<sub>4</sub></li> <li>• C<sub>2</sub>H<sub>2</sub>/CH<sub>4</sub></li> <li>• C<sub>2</sub>H<sub>6</sub>/C<sub>2</sub>H<sub>2</sub></li> <li>• C<sub>2</sub>H<sub>4</sub>/C<sub>2</sub>H<sub>6</sub></li> <li>• CO<sub>2</sub>/CO</li> </ul>

1) Calculated from 24 h average values. See standard IEC 60599.

## Operating Environment

Transformer oil type	Mineral oil
Required minimum fire point <sup>1)</sup> of transformer oil	+125 °C (+257 °F)
Transformer oil pressure at oil inlet	Max. 2 bar <sub>abs</sub> continuous Burst pressure 20 bar <sub>abs</sub>
Transformer oil temperature at oil inlet	Max. +100 °C (+212 °F)
Ambient humidity range	0 ... 100 %RH, condensing
Ambient temperature range in operation	-40 ... +55 °C (-40 ... +131 °F)
Storage temperature range	-40 ... +60 °C (-40 ... +140 °F)

1) The fire point [of transformer oil] is normally approximately 10 °C [18 °F] higher than the closed flash point. See, for example, Heathcote, Martin J. *The J & P Transformer Book*. 13th ed. Elsevier, 2007.

## Power Supply

Operating voltage	100 ... 240 VAC, 50 ... 60 Hz, ±10 %
Overvoltage category	III
Maximum current consumption	10 A
Maximum power consumption	500 W
Typical power consumption at +25 °C (+77 °F)	100 W

## Outputs

<b>RS-485 Interface</b>	
Supported protocols	Modbus RTU
Galvanic isolation	2 kV RMS, 1 min
<b>Ethernet Interface</b>	
Supported protocols	DNP3 (Distributed Network Protocol), Modbus TCP, HTTP
Galvanic isolation	4 kV AC (50 Hz, 1 min)
<b>Relay Outputs <sup>1)</sup></b>	
Number of relays	3 pcs, normally open (NO) or normally closed (NC), user selectable
Trigger type	User selectable: gas level, rate of change, or device status
Max. switching current	6 A (at 250 VAC) 2 A (at 24 VDC) 0.2 A (at 250 VDC)
<b>User Interface</b>	
Interface type	Web based user interface, can be operated with standard web browsers

1) Operation of relay outputs will be enabled by a software update.

## Mechanical Specifications

Oil fitting	Stainless steel Swagelok® fitting for 10 mm (0.39 in) outer diameter pipe. For 3/8 inch pipe, use adapter SS-600-R-10M.
Max. length of oil pipe to transformer	Max. 10 m (33 ft) with 7 mm (0.28 in) inner diameter pipe Max. 5 m (16 ft) with 4 mm (0.15 in) inner diameter pipe
Material	Marine aluminum (EN AW-5754), stainless steel AISI 316

## Type Tests

Category	Standard	Class/Level	Test
EMC compliance	IEC61000-6-5	Class 4 (interface type 4)	Immunity for Power Station and Substation Environments
	IEC61326-1	Industrial	Electrical equipment for measurement, control, and laboratory use - EMC requirements
Environmental	IEC60529	IP66 (equivalent to NEMA 4 rating)	Ingress protection
Safety	IEC/EN61010-1, 3rd edition UL 61010-1:2012 CSA C22.2 No. 61010-1-12	Compliant	Safety requirements for electrical equipment for measurement, control, and laboratory use - Part 1: General requirements

## Compliance

CE marking

EMC directive, Low voltage directive, RoHS directive, WEEE directive

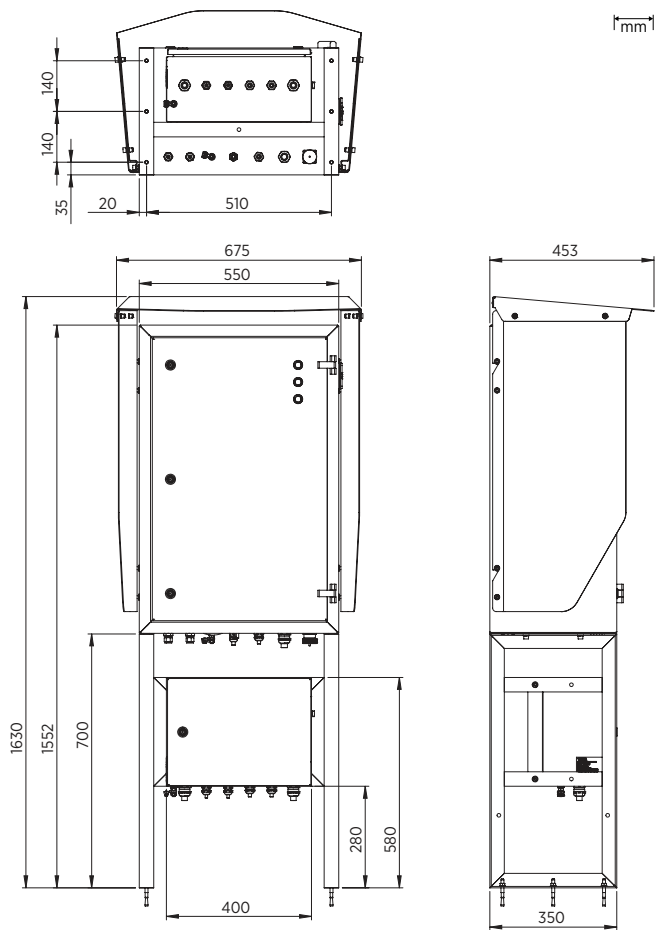

Dimensions

## You Can Count on Vaisala

Vaisala has been creating measurement devices for 80 years. Our instruments and systems are used in over 150 countries in industries where failure is not an option, including airports, pharmaceuticals, and power generation. In fact, over 10,000 companies in safety and quality-critical sectors already rely on Vaisala.

Vaisala sensors are so reliable they are used in the harshest places on earth – like arctic, maritime, and tropical environments – and even on Mars.

## Power Transformer Monitoring That Works

Vaisala Optimus™ DGA Monitor delivers out-of-the-box performance, eliminates false alarms, and gives you the best long-term stable measurements for the key fault gases used in transformer diagnostics.



**VAISALA**

www.vaisala.com

Published by Vaisala | B211583EN-E © Vaisala 2018

All rights reserved. Any logos and/or product names are trademarks of Vaisala or its individual partners. Any reproduction, transfer, distribution or storage of information contained in this document is strictly prohibited. All specifications – technical included – are subject to change without notice.