

FOOD INDUSTRY APPLICATIONS



Precision on-line
and at-line NIR
measurements

- ▶ **Moisture**
- ▶ **Fat**
- ▶ **Protein**
- ▶ **Degree of Bake/
Brownness**



- ▶ **Enhance Product Quality & Consistency**
- ▶ **Reduce Waste**
- ▶ **Develop Best Practice & Safety**
- ▶ **Increase Process Productivity**
- ▶ **Maintain Brand Competitiveness**

NDC & the Food Industry

NDC Technologies has over 40 years' experience in the design and manufacture of process instruments developed specifically to meet the exacting quality requirements of the food industry.

We use our in-depth knowledge of the physical and chemical attributes of food products, the measurement and control requirements in the process, and the many analytical methods used in quality assurance systems to develop accurate, stable and robust measurements that can be trusted for quality and process control.

We have forged successful relationships with key players in the industry, both producers and equipment manufacturers, and it is this combined technical and commercial knowledge that helped create our MM710e On-Line Food Gauge and InfraLab At-Line Food Analyzer - our 8th generation instruments - dedicated to on-line and at-line measurement in food processing.



The Need for Quality & Process Control

Maintaining consumer loyalty through consistently high product quality...

Measurements:

- ▶ **Moisture content**
- ▶ **Fat or oil content**
- ▶ **Protein content**
- ▶ **Degree of bake or surface brownness**

Applications:

- ▶ **Coffee and tea processing**
- ▶ **Confectionery**
- ▶ **Cookies and biscuits**
- ▶ **Corn wet milling**
- ▶ **Crackers and crispbreads**
- ▶ **Dairy powders**
- ▶ **Flour and grains**
- ▶ **Ingredients, seeds, nuts and spices**
- ▶ **Meat further processing**
- ▶ **Olive oil extraction**
- ▶ **Pet foods and animal feeds**
- ▶ **Potato chips and crisps**
- ▶ **Snack products, baked or fried**
- ▶ **Starch**
- ▶ **Sugar processing and refining**

The **food industry** faces many challenges as it strives to ensure consistent product quality, strong customer loyalty and maximum production efficiency.

In-process measurement and close control of critical process parameters, such as moisture, fat or protein, present significant opportunity for foods manufacturers to achieve quality and production goals.

The complexity and diversity of food products and production methods, however, mean a generic approach to process measurement cannot work.

Specifically engineered solutions are needed at various stages of the process, such as: preparation of ingredients, mixing, forming, wetting, drying, baking or frying and flavoring, sorting and weighing.

At each stage, the product appears in different forms, such as a powder, slurry, dough, flake, granule or final product. At the required point of measurement, the product may be transported on an open conveyor belt or in an enclosed duct, and the product flow may be continuous or discontinuous, and ambient process conditions such as temperature and relative humidity can also change.

The product itself can vary due to seasonal changes, crop year differences and raw material supply variations.

NDC understands these factors and we engineer the robustness into our measurement solutions that ensures that changes in the measurement output are due solely to varying levels of the measured parameter, without influence from other product or process variables.



The MM710e On-line Food Gauge

Long-term calibration stability means MM710e is trusted for process control...

The **MM710e On-Line Food Gauge** uses precision NIR (near infrared) measurement technology to make a continuous single or multi-component non-contacting measurement of parameters such as:

- ▶ **Moisture**
- ▶ **Fat**
- ▶ **Protein**

With a measurement speed of 7.5 milliseconds, the patented "light engine" uses optical components manufactured in NDC's own optics facility to deliver high resolution on-line NIR measurements.

The MM710e can be incorporated conveniently into closed-loop control systems. Its connectivity options include:

- ▶ **Digital**
- ▶ **Analog**
- ▶ **Industrial Ethernet**
- ▶ **Fieldbus**

Using industry-standard Ethernet communication hardware such as hubs, cables, repeaters and routers, installation and integration of the modular MM710e gauging system is straightforward.

For network integration, the Gauge can be configured for the following industrial Ethernet protocols:

- ▶ **EtherNet IP**
- ▶ **PROFINET**
- ▶ **Modbus/TCP**

If Fieldbus connectivity is required, the OWS, HMI and User Port can be supplied with Network Gateways for:

- ▶ **PROFIBUS DP**
- ▶ **DeviceNet**
- ▶ **CANbus Open**



MM710e: Key Features & Options

- ▶ **Series 710e devices** for interfacing, connectivity and networking
- ▶ **Ethernet, Fieldbus and analog connectivity** options for networking and integration
- ▶ **IP65 & IP67 housings** cast alloy or stainless steel
- ▶ **Auto reference standard** for routine stability checks and standardization after source change
- ▶ **Air and water cooling** options for > 50° C ambient temperatures
- ▶ **PowderVision sampler** for products in enclosed ducts
- ▶ **Air Purge Window Shield** for dusty or steamy atmospheres
- ▶ **ATEX certified system** for dust hazard areas

MM710e: Key Features & Options

MM710e is also able to use light in the visible spectrum to measure:

- ▶ Degree of bake or
- ▶ Surface brownness

in baked or fried products, which, combined with moisture, fat or protein measurements, gives an even deeper insight into the process.

710e Devices and Networks

Easy to install, integrate and operate, the MM710e is the most flexible in-process gauging system available...

Convenient interfacing: what you need, where you need it

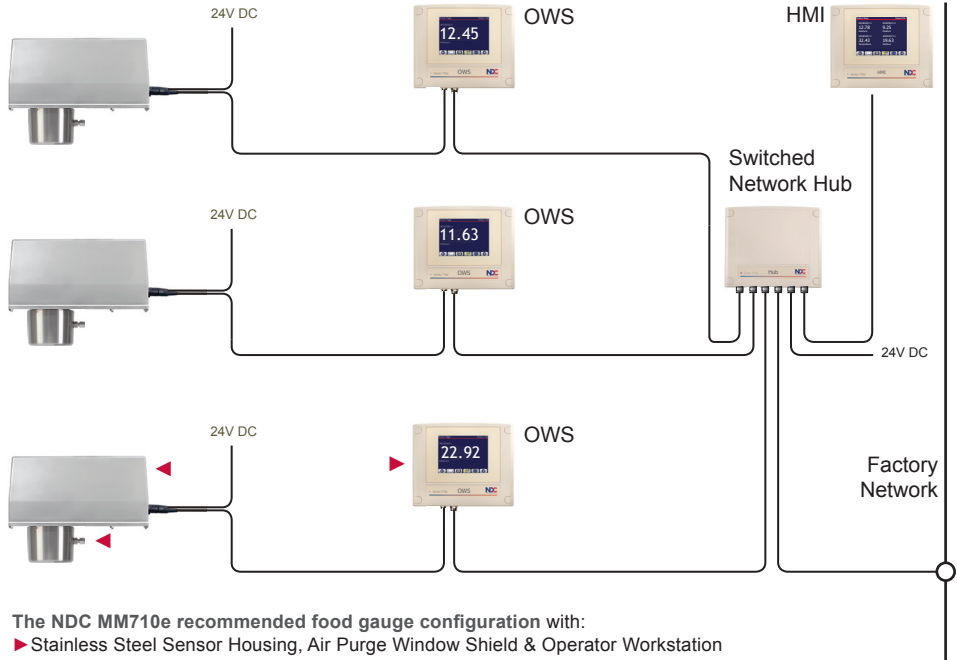

The NDC MM710e recommended food gauge configuration with:
 ▶ Stainless Steel Sensor Housing, Air Purge Window Shield & Operator Workstation

710e HMI



- ▶ ¼ VGA color touchscreen
- ▶ Analog and Ethernet connections
- ▶ Controls up to 16 gauges
- ▶ Multi-lingual interface

710e Devices

Series 710e Peripheral Devices available include:

- ▶ OWS: Operator Workstation
- ▶ HMI: Human Machine Interface
- ▶ User Port
- ▶ Switched 7-Way Switched Hub

The OWS provides operator-level interaction with an individual gauge with access to sampling and diagnostic functions.

The HMI provides supervisory access to up to 16 networked MM710e gauges to enable gauge set-up, calibration adjustment, and product management, with analog and digital connectivity as well as network access. Both HMI and OWS feature high-definition multi-lingual color touchscreen displays.

The User Port provides additional analog outputs and digital I/O for any connected gauge. The Switched Network Hub enables convenient networked arrangements of multiple 710e gauges and devices, with its 7 network connections.

For simplicity and convenience, all MM710e gauges and devices run on 24V DC, either from an on-site supply or from an NDC in-line 24V universal power supply.

Long-term stability combined with industry-best performance, low installation costs and no routine maintenance requirements guarantee the lowest cost of ownership over the MM710e's many years of service.

The MM710e in the Process

Fully engineered for continuous or discontinuous product flows

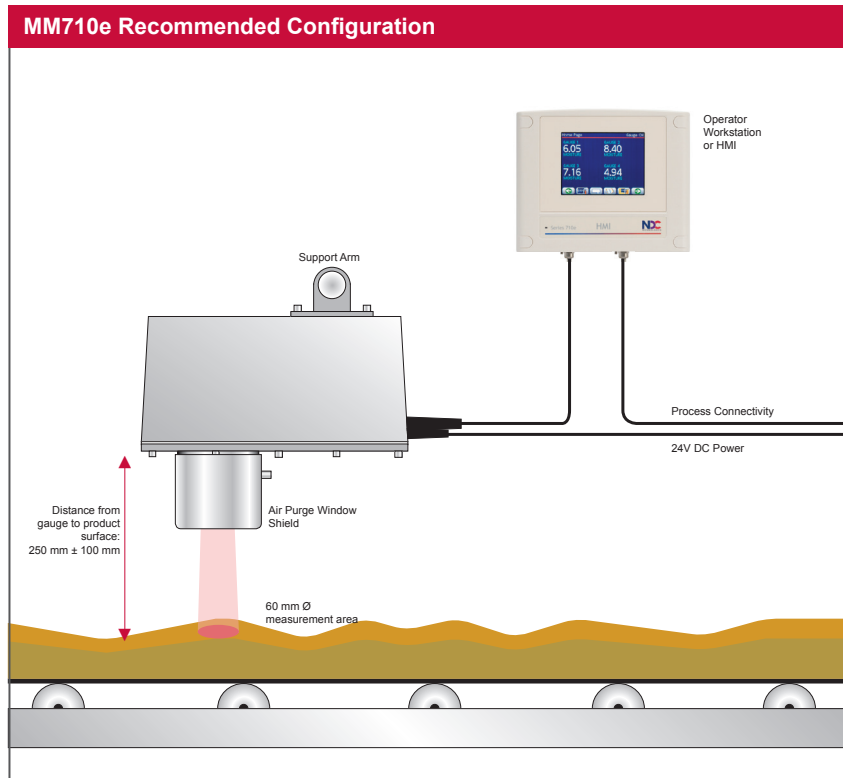

Installation

The MM710e measures over a 60 mm diameter area (optionally 25 mm or 10 mm) and is suspended over the process line at a distance of 250 mm from the mean product height to the MM710e measurement window.

The gauge tolerates product height fluctuations of ±100mm, without the measurement being affected.

Ambient lighting, temperature or relative humidity changes do not affect the MM710e measurement.

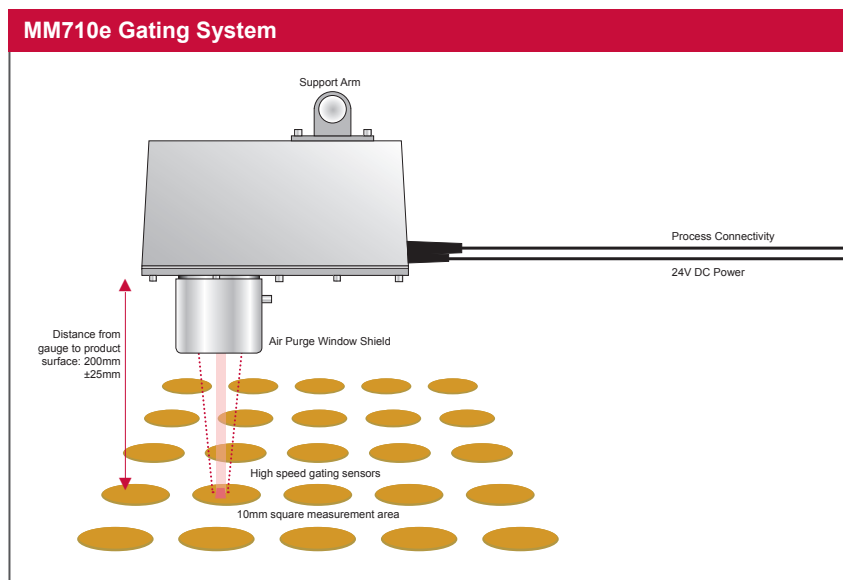

Discontinuous product flows

The optional integrated “high speed gating” system detects the product’s presence or absence in discontinuous flows and avoids recording of data when nothing is passing across the measurement area.

High-speed gating can be used for products such as cookies, biscuits or crackers as shown here, or for processes which simply do not flow continuously. 60 mm or 10 mm beam patch sizes are available.

The MM710e in the Process

Used with a PowderVision sampler in gravity-fed product flows

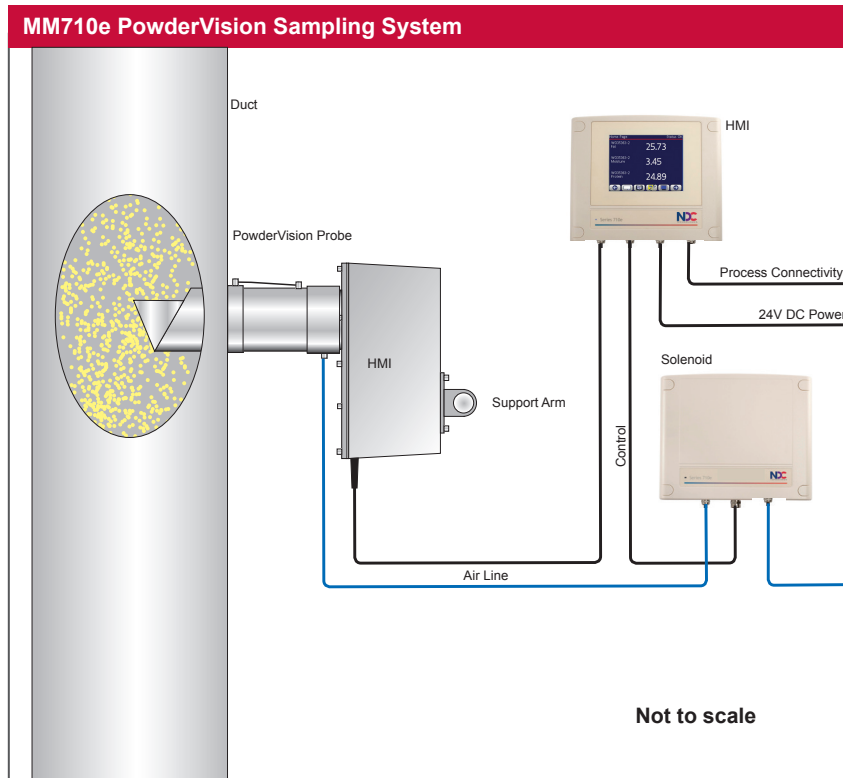

Measuring powders in gravity-fed ducts

For powders transported in enclosed ducts, the pneumatic PowderVision sampler is used. The device comprises a tube fitting with window and sample collection cup. The cup fills with the falling product, and, after a sample has been collected and measured, a jet of air ejects it and the cycle recommences.

Process Conditions



TEMPERATURE



DUST



AMBIENT LIGHT



HUMIDITY

The MM710e's alloy or stainless steel housings are sealed to IP65 and can operate in ambient temperatures from 0° to 50° C without cooling. The stainless steel housing is also available in IP67 and ATEX certified versions.

A vortex cooler attachment or insulated air-cooled housing are available for ambient temperatures exceeding 50° C. The optional Air Purge Window Shield connects to a clean air supply to create a positive air pressure in front of the measurement window to prevent contamination.

Additional technical information sources

For additional technical information about installation, calibration, networking and process connectivity, and the MM710e generally, please consult the manuals.

The InfraLab Food Analyzer

Fast, accurate and easy to operate, InfraLab is the viable alternative to laboratory methods

Key Features

- ▶ **Color VGA touchscreen** interface
- ▶ **InfraLab Manager software** for data management via PC
- ▶ **Ethernet and LIMS** connectivity for factory or laboratory network integration
- ▶ **On-board data storage** of up to 10,000 sample measurement files
- ▶ **Up to 200 users** with individual pass code and specific access permissions
- ▶ **Product database** for up to 200 products with specific settings for each
- ▶ **USB data port** for data download to spreadsheet programs
- ▶ **Barcode reader option** making log-in and product selection even easier
- ▶ **Reference standard** for routine stability checks and standardization after servicing
- ▶ **Choice of sample bowl size** deep, shallow (rotating) or petri-dish (static)
- ▶ **Measurement Speed** 5 seconds or 10 seconds (application dependent)
- ▶ **History Audit Log** of calibration records and Reference Standard values

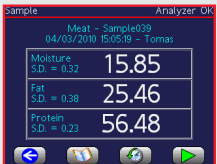

1/4 VGA Color Touchscreen Display



Data Download to USB Memory Stick



Reference Standard (option)



Bar Code Reader (option)

The InfraLab e-Series food analyzer, designed for both at-line and laboratory use, measures samples taken from the process in less than 10 seconds. Available in single or multi-component formats, InfraLab is able to simultaneously analyze:

- ▶ Moisture
- ▶ Fat
- ▶ Protein

InfraLab is designed as a routine replacement for loss-on-drying, Karl Fischer or gravimetric moisture testing, and to replace chemical methods for fat or protein analysis such as Soxhlet, Weibull-Stoldt or Kjeldahl.

Once calibrated to your preferred reference methods, a process facilitated by the InfraLab Manager software, its key advantages are: speed, minimal sample preparation and the fact that it measures a larger, more representative sample than other techniques.

InfraLab is accessed via its intuitive interface and requires no special user skills in routine use.

Secure data storage

In addition to its speed and precision, InfraLab benefits from substantial data storage and security features.

A unique sample identifier, plus the time and date of every measurement are recorded together with the name of the operator who is logged in at the time.

5 year consumables warranty

The source lamp and motor are guaranteed for 5 years and can be exchanged quickly and easily on site without intervention from NDC.

Ethernet connectivity

enables InfraLab to be used either as a standalone analyzer or integrated into LIMS or factory networks, or simply connected to a PC when required to take advantage of the features offered by the InfraLab Manager software.

InfraLab Manager Software

provides user access to all measurement and calibration data and enables set-up and remote access to data and key functions. It enables up to 16 networked analyzers to be controlled and viewed centrally from a PC.

InfraLab's rapid analysis capability delivers substantial savings through reduction in costs of routine sample testing



Measured by Commitment

At-Line in the Process Area or in the Laboratory

Access data quickly and easily via Ethernet networking or USB download



InfraLab Manager Software

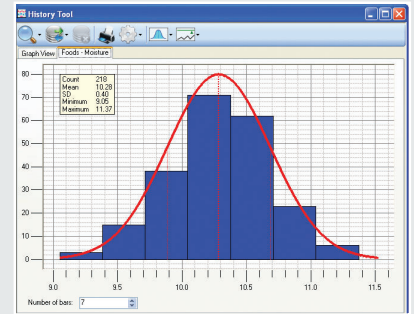

► Histogram

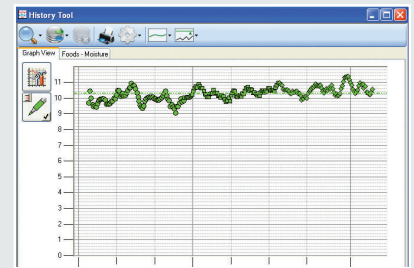

► Data display

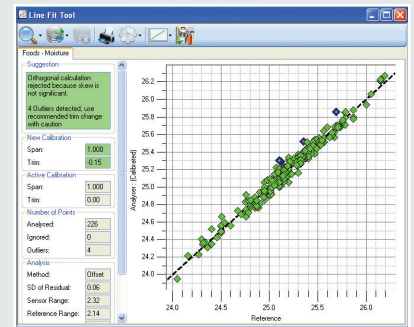

► Calibration

Network Connectivity

Ethernet



PC running "InfraLab Manager" software



Food Industry Applications

Comprehensive applications engineering
for high performance process measurements

NDC Food Applications						
Food Industry Sector	On-Line	At-line	Moisture	Fat	Protein	Application Areas
Breakfast Cereals	■	■	✓			breakfast cereals - corn, wheat or rice based
Cheese Processing		■	✓	✓	✓	cottage cheese, cream cheese, mozzarella, hard and semi-hard cheeses
Chocolate Making	■	■	✓	✓		cocoa beans, cocoa liquor, cocoa powder, drinking chocolate, molten chocolate, crumb
Coffee and Tea Processing	■	■	✓			green beans, ground roast coffee, instant coffee, instant tea, finished tea leaf
Confectionery	■	■	✓			sugar coatings, molding starch, fondant cream
Cookies and Biscuits	■	■	✓			cookies - wire cut, biscuits
Corn & Maize Wet Milling	■	■	✓	✓	✓	starch, modified starch, sweeteners, gluten, germ, maize fiber
Crackers and Crispbreads	■	■	✓			sweet or savory crackers, Scandinavian crispbreads
Dairy Powders	■	■	✓	✓	✓	casein, lactose, milk powder, infant formulae, non-dairy creamer
Flour and Grains	■	■	✓	✓	✓	rice, wheat flour (white or wholemeal), soya flour, oat flakes, whole wheat or barley, wheat gluten
Ingredients, Seeds, Nuts and Spices	■	■	✓	✓		sunflower seeds or meal, shea nuts, sesame seeds, spices, yeast, nuts, palm fiber
Meat Further Processing		■	✓	✓	✓	ground beef, pork, lamb, poultry, meat cuts, mechanically reclaimed meat products
Olive Oil Extraction	■	■	✓	✓		olive pomace or "orujo" during virgin oil and standard oil extraction processes
Pet Foods and Animal Feeds	■	■	✓			pellets, dry feeds, dog biscuits, alfalfa, lucerne, distiller's grains, spent grains, bagasse, brewery waste, coffee waste
Potato Chips and Crisps	■	■	✓	✓		fried potato chips or crisps, baked potato chips or crisps, hand-cooked chips
Snack Products, baked or fried	■	■	✓	✓		corn chips, tortilla chips, corn dough, puffed corn snacks, popcorn, pretzels
Starch	■	■	✓			corn starch, potato starch, wheat starch
Sugar Processing and Refining	■	■	✓			granulated sugar, caster sugar, brown sugar, sugar cubes

Calibration Software

MM710e & InfraLab are delivered with NDC's "SpeedCal" pre-calibrations ready for use for the specified measurement(s) and range(s). The GaugeToolsXL (for MM710e) and InfraLab Manager software provided facilitates the calibration process by enabling comparison of instrument values with laboratory results and features the following tools and functionality:

- ▶ Instrument Set-up and Calibration
- ▶ Product Management (Product Settings)
- ▶ Displays of Measurement and other Key Parameters
- ▶ Data Logging and Data Trending & Export
- ▶ Diagnostic Functions
- ▶ OPC Server (optional)

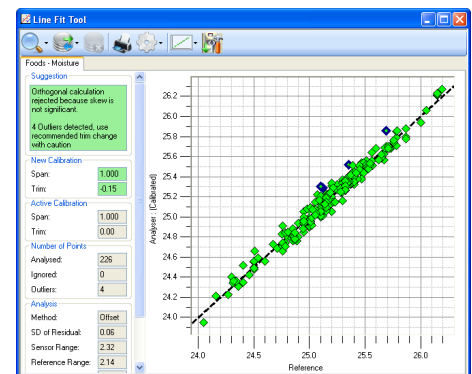

Company overview

Combining industry-best performance and reliability with a global support structure

NDC Technologies, headquartered in Irwindale, California, designs, develops and produces a wide range of process measurement and control instrumentation for a broad scope of manufacturing industries.

NDC has manufacturing facilities in California, Dayton, Ohio and Maldon, UK, with centers of excellence at each of these locations including Loncin, Belgium. In addition, there are direct sales and support facilities in China, Japan, France, Germany and Italy. There is also a highly trained network of Sales and Service distribution channels in more than 60 countries around the world.

NDC Technologies is structured to serve its key industry segments with two distinct business units:

► Food, Bulk and Packaging

In packaging, NDC provides basis weight, thickness, coat weight and moisture measurement and control systems for a diverse array of applications in the converting and film extrusion industries and also provides solutions for customers in nonwovens and calendering.

For the food and bulk industries, NDC delivers both on-line and at-process analyzers for the measurement of key constituents such as moisture, fat, oil and protein. NDC's broad spectrum of measurement solutions are used in the food, chemicals, minerals building materials, pharmaceutical and tobacco industries.

► Cable, Metals and Tubing

In the steel and aluminium industries, NDC offers advanced solutions for the measurement of thickness, width, flatness, edge shape, coatings, and length and speed of sheet and long casted products.

NDC serves the wire, cable, fiber optic, pipe and tube industries with a broad portfolio of on-line and off-line measurement and control solutions for the dimensional monitoring of diameter, ovality, wall thickness, eccentricity, length and speed, and other parameters.



NDC Technologies is represented in over 60 countries worldwide. www.ndc.com

a **spectris** company

NDC Technologies Inc.

Tel: +1 626 960 3300
Email: info@ndc.com

NDC Technologies sa

Tel: +32 4 239 90 10
Email: sales@ndcinfra.be

NDC China

Tel: +86 20 2887 3860
Email: info@ndcinfra.com.cn

NDC Germany

Tel: +49 1801 977112
Email: ndcgermany@ndc.com

NDC Singapore

Tel: +65 91994120
Email: apacsales@ndc.com

NDC Technologies Ltd

Tel: +44 1621 852244
Email: enquiries@ndc.com

NDC Beta LaserMike

Tel: +1 937 233 9935
Email: sales@betalasermike.com

NDC Japan

Tel: +81 3 3255 8157
Email: ndcjapan@ndc.com

NDC Italy

Tel: +39 0331 454 207
Email: ndcitaly@ndc.com

NDC India

Tel: +91 9890800697
Email: ndcindia@ndc.com



In line with its policy of continuous improvement, NDC reserves the right to revise or replace its products or services without prior notice. The information contained in this document may not represent the latest specification and is for indicative purposes only.

Document Number: IB-01-15525-02-2015-03
Date of Issue: March 2015
© NDC Technologies 2015